

SBURON

Air Conditioner Cooling & Heating
Climatizzatore Caldo e Freddo



Position in the cabin
Posizione in cabina



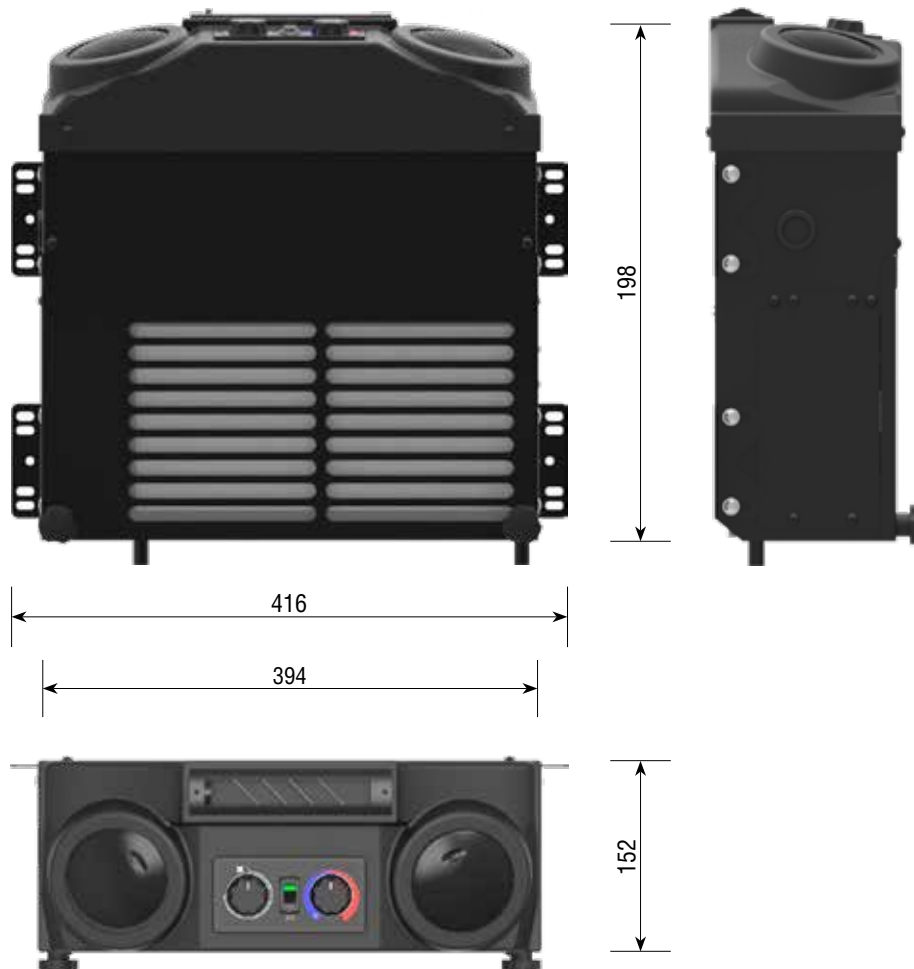

Flange expansion valve

Valvola espansione flangiata





Water connector diameter 10 or 16 mm

Connettori acqua diametro 10 o 16 mm

SBURON Air Conditioner Cooling & Heating / Climatizzatore Caldo e Freddo

HVAC  Cooling & Heating / Freddo e Caldo

	Part. Codice	Voltage Voltaggio	Ampere Amperaggio	Cooling Freddo	Heater Caldo	Air m ³ /h Aria m ³ /h	Weight Peso	Case Rivestimento
	A0CF00201ES	12 V	15 A	8.5 kW	7.5 kW	750	9.8 kg	Painted sheet metal
	A0CF00202ES	24 V	8 A	8.5 kW	7.5 kW	750	9.8 kg	Painted sheet metal
	A0FF00201ES	12 V	15 A	8.5 kW	-	750	9.8 kg	Painted sheet metal
	A0FF00202ES	24 V	8 A	8.5 kW	-	750	9.8 kg	Painted sheet metal